

EWSJ-363

Integrated Outdoor Speed Dome Camera



FEATURES

- 1/4" 613K pixels SONY Super HAD II dual scan CCD
- 700TV lines of highest resolution - HR7 mode
- Progressive scan 612,688 pixel
- Optical 36x power zoom and 32x digital zoom
- Dual scan 512x WDR
- Intelligent detection for baggage removal and loading(Option)
- IP66 Outdoor Application
- 255 Presets - Pan : 380°/sec $\pm 0.1^\circ$, Tilt : 150°/sec $\pm 0.01^\circ$ Accuracy - 64 steps proportional to zoom
- 8 programmable Tours
- 4 Patterns
- Digital Auto Flip
- Polycarbonate Dome Cover (166 \emptyset)
- 8 Alarm Inputs(Normal Open or Normal Close), 2 relay outputs
- 8 Auto Scan(Programmable speed and diagonal scan)
- Pan Motion Allows 0.1-90°/sec Pan Speed
- Programmable Privacy Masking(8 Zones)
- RS-422, RS-485 communication support and remote program update
- Multiple protocol
- Built-in Menu System for Setup of Programmable Functions
- Programmable Zoom Speeds
- AC 24V, 1A / AC 24V, 2A(Outdoor Housing)
- Digital Noise Reduction (2D + 3D)
- Digital Image Stabilizer (DIS)
- High Light Compensation (HLC) Function

DIMENSIONS

Unit : mm

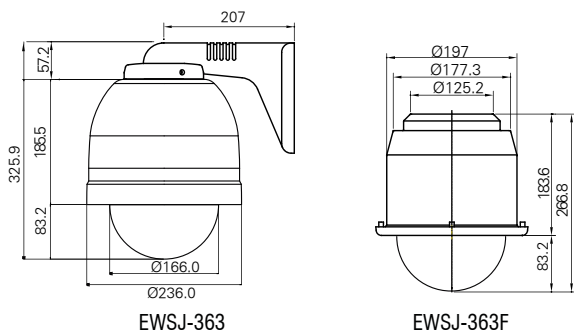

- Effio DSP
- 960H(611,688 Pixels)
- 36X Optical Zoom
- 700TV Lines
- Support WDR

SPECIFICATIONS

MECHANICAL / ENVIRONMENTAL	
Pan	360° Continuous Pan 0.1° to 90°/sec (64 steps proportional to zoom)
Pan Preset Speed	380°/sec, $\pm 0.1^\circ$ Accuracy
Tilt	0.1° to 90°/sec. (64 steps proportional to zoom)
Tilt Preset Speed	150°/sec, $\pm 0.01^\circ$ Accuracy
Weight	Approx. 4.4Kg (10.8 lbs) / Packing : 4.9Kg
Dimensions	236(\emptyset) x 325.9(H) mm – 166(\emptyset) dome
Construction	Aluminum
Ingress Protection	IP66 (Outdoor Housing)
Color	Cool gray
Operating Temp	-20°C to 50°C (Fan&Heater power ON)
Storage Temp	-10°C to 50°C (14° F to 122° F)
Humidity	0% to 90% (non-condensing)

FUNCTIONS	
Preset	255 points less than 0.1° accuracy
Tour	8 programmable
Pattern	4 patterns for 240 second.
Flip	Digital ON/OFF
Scan	8 (programmable speed and diagonal scan)
Privacy Zone	Programmable up to 8
ID Address	Up to 255 selectable ID (Rotary switch)
Data Communication	RS-485 / RS-422
Protocol	Multiple protocol (PELCO-D/P, WONWOOD)
Baud rate	2400, 4800, 9600, 19200, 38400, 57600 bps selectable
Alarm In	8 alarm
Alarm Out	2 relay out
Display	16 Area title

ELECTRICAL / USER CONNECTIONS	
Power	21~28VAC 60Hz / 50Hz(Power adaptor not included)
Camera	18.0W
Heater	33W or 62.7W, Fan Power Consumption: 3.4W
RS-422, 485	Dip Switch setting
RS-485, 422	RS-422, 485 + / - Optional Control Data
Video connection	BNC
Alarm Inputs	8 Programmable
Relay Out	2 Dry Contact Output Rating: 2A @30VAC

CERTIFICATION : CE, FCC CLASS A, RoHS

DC 12V Optional

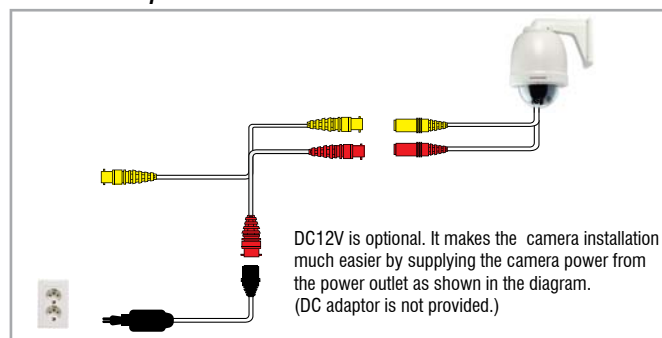

EWSJ-363

Integrated Outdoor Speed Dome Camera

CAMERA SELECTION

MODEL	EWSJ-363N / EWSJ-363P	EWSJ-333N / EWSJ-333P	EWSJ-283N / EWSJ-283P
Image Sensor	1/4" Sony Super HAD II CCD	1/4" Sony Super HAD II CCD	1/4" Sony Super HAD II CCD
Lens	36x Optical, Digital 32x	33x Optical, Digital 32x	28x Optical, Digital 32x
Focal Length	f=3.4mm~122.4mm (F1.6 to 4.5)	f3.4~115.5mm (F 1.6 to 3.6)	f=3.4mm~98mm (F 1.6 to 3.2)
Aperture Ratio	f1.6(WIDE) ~ f4.5(TELE)	f1.6(WIDE) ~ f3.6(TELE)	f1.6(WIDE) ~ f3.2(TELE)
Min. Focus distance	100mm	100mm	100mm
Total pixels	NTSC: 1028x508 / PAL: 1028x596	NTSC: 1028x508 / PAL: 1028x596	NTSC: 1028x508 / PAL: 1028x596
Resolution	Color: Max 700TV Lines @ HR7 mode B/W: Max 750TV Lines @ HR7 mode	Color: Max 700TV Lines @ HR7 mode B/W: Max 750TV Lines @ HR7 mode	Color: Max 700TV Lines @ HR7 mode B/W: Max 750TV Lines @ HR7 mode
Min. illumination	Color DSS : 0.001 lux, BW ESS : 0.0004 lux Color : 0.5 lux, BW : 0.2 lux	Color DSS : 0.001 lux, BW ESS : 0.0004 lux Color : 0.5 lux, BW : 0.2 lux	Color DSS : 0.001 lux, BW ESS : 0.0004 lux Color : 0.5 lux, BW : 0.2 lux
Video Output	1.0 Vp-p (75Ω, composite)	1.0 Vp-p (75Ω, composite)	1.0 Vp-p (75Ω, composite)
S/N Ratio	More than 50dB(AGC off)	More than 50dB(AGC off)	More than 50dB(AGC off)
Electronic Shutter	NTSC : 1/60 ~ 1/100,000 sec PAL : 1/50 ~ 1/100,000 sec	NTSC : 1/60 ~ 1/100,000 sec PAL : 1/50 ~ 1/100,000 sec	NTSC : 1/60 ~ 1/100,000 sec PAL : 1/50 ~ 1/100,000 sec
Privacy Function	programmable up to 8	programmable up to 8	programmable up to 8
Flip	ON/OFF	ON/OFF	ON/OFF
DNR	OFF/MANUAL/AUTO	OFF/MANUAL/AUTO	OFF/MANUAL/AUTO
Day/Night	Auto/Sens-in/Ext/Day/Night	Auto/Sens-in/Ext/Day/Night	Auto/Sens-in/Ext/Day/Night
White Balance	ATW/One-push/Indoor/Outdoor/Manual/Auto	ATW/One-push/Indoor/Outdoor/Manual/Auto	ATW/One-push/Indoor/Outdoor/Manual/Auto
Back Light	WDR/BLC/OFF	WDR/BLC/OFF	WDR/BLC/OFF
Lens Initialize	built-in	Built-in	Built-in
Iris	1~18	1~18	1~18
Gain Control	OFF/ON(AUTO MAX 32dB)	OFF/ON(AUTO MAX 32dB)	OFF/ON(AUTO MAX 32dB)
OSD Display	ON/OFF	ON/OFF	ON/OFF
Special features	WDR	ON/OFF	ON/OFF
	HLC	ON/OFF	ON/OFF
	Mirror	ON/OFF	ON/OFF
	Freeze	ON/OFF	ON/OFF
	DIS	ON/OFF	ON/OFF

700TV Lines High Resolution Image

These cameras combine a Sony "Effio" DSP with a 1/4-type Super HAD II CCD®. They achieve a high horizontal resolution of 700 TV lines with 611, 688 pixels CCD, enabling reproduction of amazingly clear and detailed images.



Color Reproduction

Color reproduction of other cameras only looks flashy. The "A" portion should be actually yellow and red, however, it washes out due to white saturation. In addition, the amount of aperture signal is large, making the edges worse (see the "B" portion). Even if the aperture level drops, the images become blurry.

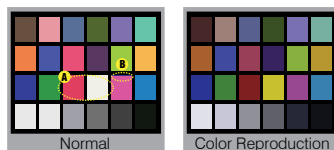

Wide Dynamic Range Image

These cameras incorporate an advanced backlight compensation technology that dramatically improves each camera's dynamic range by 512 times when compared to conventional cameras. Thanks to this new technology, users can capture clear images even in extreme high-contrast lighting environments. The cameras capture the same image twice: first with a normal shutter speed, and then with a high shutter speed.

The dark areas captured at normal shutter speed and the bright areas captured at high shutter speed are then combined into one image using an advanced DSP Effio, which clearly reproduces the original scene.



Auto ICR

These cameras offer optimal sensitivity in both day and night shooting applications. At a set level of darkness, the IR-cut filter is automatically disabled (ICR ON) and the near-infrared sensitivity is increased. At a set level of brightness, the filter is automatically enabled (ICR OFF). The IR-cut filter automatically engages depending on the ambient light, allowing the camera 24/7 operation in a variety of lighting conditions.

32x E-Zoom

Provides more recognizable pictures after E-zoom due to 960 effective vertical pixels.